

# Adjust-A-Rolls®

**SUMNER**



Hi Adjust-A-Roll (31")

Lo Adjust-A-Roll (24")

Table Adjust-A-Roll

**New Adjust-A-Roll feature!**  
Replacement legs for easy repair  
(p/n 780675-KD)



- ✓ Roller adjustment from either side
- ✓ Fast adjustment for easy pipe positioning
- ✓ 1/2 to 36" ( 1.2 - 91 cm), or 2,000 lb (900 kg) pipe capacity
- ✓ Clean and simple design avoids welder interference

- ✓ Wheels trued for true pipe rotation
- ✓ Bronze bearing to eliminate arcing
- ✓ Brake to lock loads for lay-out or fit-up
- ✓ Handle large enough to work with gloved hand

## Pro Roll™

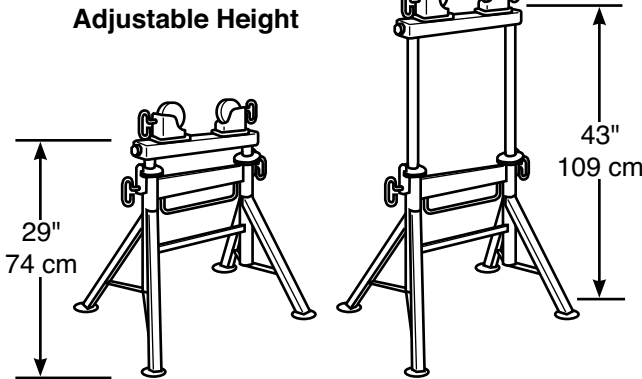

- ✓ More features
- ✓ Adjustable height
- ✓ 1/2" - 36" (1.2 - 91 cm) or 2,000 lb (900 kg) capacity
- ✓ Leveling on either side of stand
- ✓ Uses Quick Change Housings

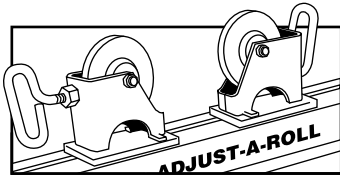

**Carbon Steel or Stainless Steel Roller Head**  
2,000 lb (900 kg) capacity

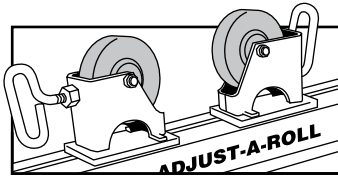

**Rubber Wheel Roller Head**  
1,200 lb (550 kg) capacity

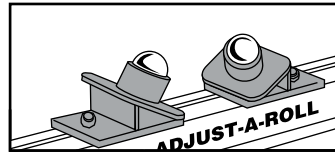

**Ball Transfer Roller Head**  
1,000 lb (450 kg) capacity  
carbon or stainless steel balls

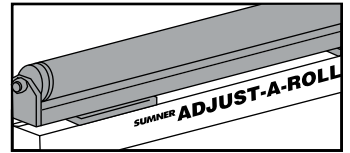

**Bar Stock Head**  
2,000 lb (900 kg) capacity  
Two position roller for containment or non-containment of material

- ✓ Wheels "trued" for even pipe rotation
- ✓ Bronze bearings to eliminate arcing
- ✓ Brake to lock loads for lay-out or fit-up
- ✓ Handles large enough to grip with a gloved hand
- ✓ Quick Change design increases roller stand utility

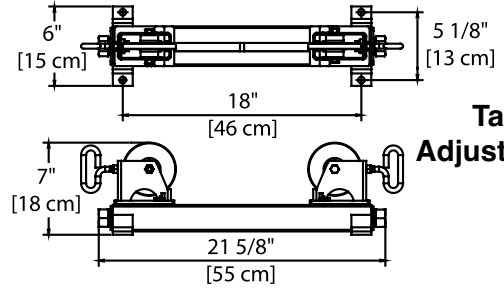

**Table Adjust-A-Roll**

## Hi Adjust-A-Roll

Part No.	Description	Weight	
		Lb.	Kg.
780365	ST-601 with steel wheels	34.0	15.4
780366	ST-602 with ball transfer heads	33.0	15.1
780367	ST-603 with rubber wheels	33.0	15.1
780368	ST-604 with stainless steel wheels	33.0	15.1
780369	ST-605 with bar stock head	40.0	18.2
780399	Hi Adjust-A-Roll [base only]	24.0	10.9

## Lo Adjust-A-Roll

Part No.	Description	Weight	
		Lb.	Kg.
780370	ST-701 with steel wheels	29.0	13.2
780371	ST-702 with ball transfer heads	31.0	14.1
780372	ST-703 with rubber wheels	31.0	14.1
780373	ST-704 with stainless steel wheels	31.0	14.1
780359	ST-705 with bar stock head	38.0	17.3
780405	Lo Adjust-A-Roll [base only]	12.0	5.5

## Table Adjust-A-Roll

Part No.	Description	Weight	
		Lb.	Kg.
780360	ST-501 with steel wheels	20.0	9.0
780361	ST-502 with ball transfer heads	18.0	8.2
780362	ST-503 with rubber wheels	19.0	8.6
780363	ST-504 with stainless steel wheels	20.0	9.0
780364	ST-505 with bar stock head	26.0	11.8
780500	Table Adjust-A-Roll [base only]	12.0	5.5

## Pro Roll

Part No.	Description	Weight	
		Lb.	Kg.
780440	Pro Roll [base only]	20.0	9.0
780441	Pro Roll with steel wheels	18.0	8.2
780442	Pro Roll with ball transfer heads	19.0	8.6
780443	Pro Roll with rubber wheels	20.0	9.0
780444	Pro Roll with stainless steel wheels	26.0	11.8
780446	Pro Roll with bar stock head	12.0	5.5

Hi Adjust-A-Roll, Lo Adjust-A-Roll, and Pro Roll have a width of 31" (80 cm) and a depth of 23" (58.5 cm).

# Quick Change Roller Housings

for Sumner Pro Roll and Adjust-A-Rolls

Sumner's innovative Quick Change Roller Housings increase the utility of its roller stand product line. Roller housings can be changed in a snap, without tools, to adapt to changing job needs. Roller wheels available in steel, stainless steel or rubber. Ball transfer heads, with carbon or stainless steel balls, and bar stock heads are also available.



Patent Pending

Part No.	Description	Weight	
		Lb.	Kg.
783151	Quick Change Housing with steel wheels	8.0	3.6
783152	Quick Change Housing with rubber wheels	7.0	3.2
783153	Quick Change Housing with stainless steel wheels	8.0	3.6
783154	Quick Change Housing with ball transfer head	7.0	3.2
783155	Quick Change Housing with bar stock head	16.0	7.2
783159	Quick Change Housing with stainless steel ball transfer head	7.0	3.2